

1. Insert a screwdriver (or any flat object) under the edge of the lid's handle.

2. Push down on the screwdriver handle to pop the lid handle up.

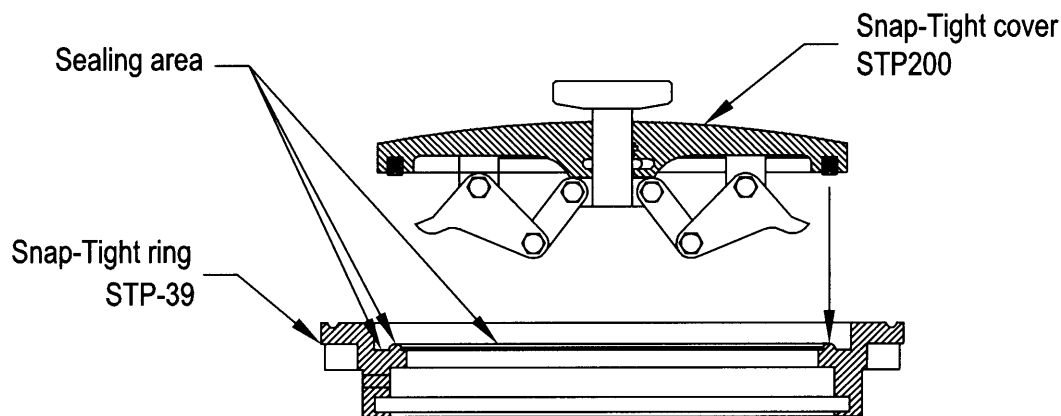

3. Use a paint brush to sweep all sand and dirt from the sealing area of the fill cover every time you remove the cover. This will ensure a tight seal and keep rain water from intruding into the containment area.

4. We recommend using Mobil synthetic or equal to grease shaft on the Snap-Tight cover once a year for easy movement. Also spray WD-40 or equal on the shaft at least once a week, as shown below. (Fig. 1)

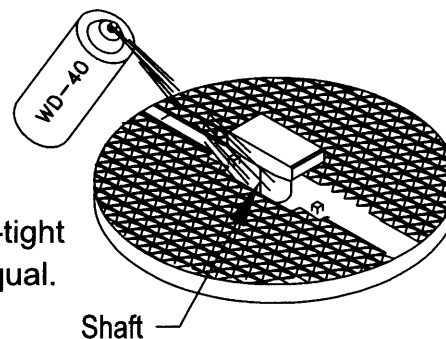

FIG. 1

### IMPORTANT NOTE:

For freezing weather areas, spray around snap-tight cover with VICTOR LOCK DE ICER spray or equal.