

## GRAVITY COVER

# INSTALLATION INSTRUCTIONS WITH NEW STYLE BELLOWS FOR ALL CONTAINMENT BOXES WITH IN-LINE DRAIN FLANGES

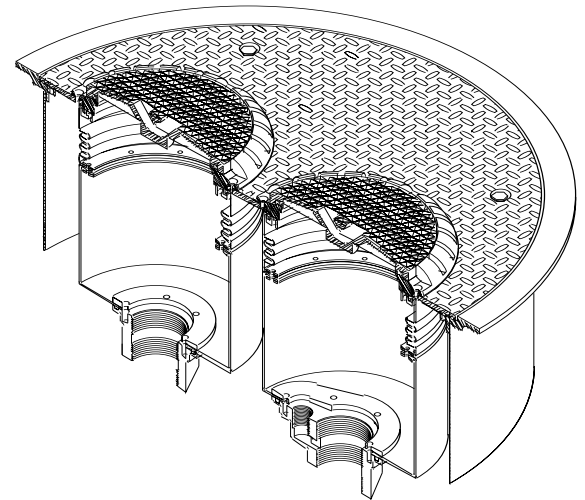

**DRAIN VALVE ASS'Y--(F): TWO PIECE HARD COAT ANODIZED ALUMINUM C.A.R.B. APPROVED.**

ON ALL NEW ROUND CONTAINMENTS THAT ARE COMPLETELY ASSEMBLED, THEY ARE READY TO BE INSTALLED ON THE RISERS WITHOUT BREAKING THEM DOWN. MAKE SURE AND ALLOW FROM THE TOP OF THE MANHOLE COVER AND THE BOTTOM OF THE FLANGE 19.00" FOR 5 GAL. AND 31.00" FOR 15 GAL. THIS DOES NOT INCLUDE THE AMOUNT OF THREADS PER RISER THAT ARE SCREWED IN.

ALWAYS USE ANTI-SEIZE COMPOUND ON ALL THREADED AREAS SUCH AS BOLTS AND NUTS.

**CONTAINMENTS SHIPPED  
ASSEMBLED AS SHOWN BELOW**

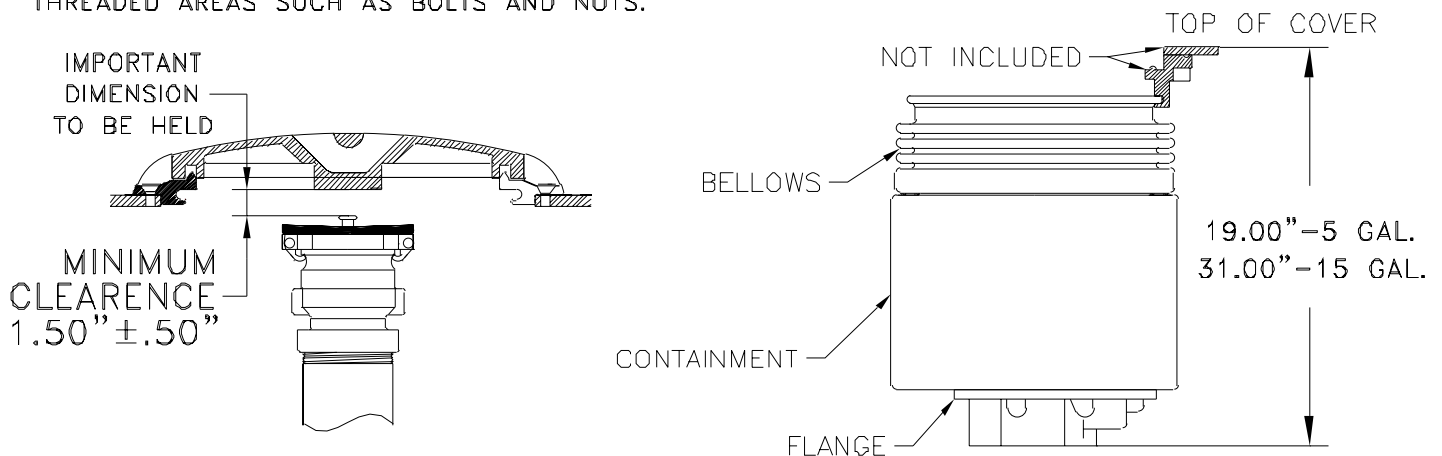

**IMPORTANT!**

APPLY A GOOD TEFLON FIRE MARSHAL APPROVED THREAD SEALING COMPOUND ON RISER THREADED AREA.

- 1) USING TWO PEOPLE, LIFT THE MANHOLE- (A) AND PLACE OVER THE CONTAINMENT. ALIGN THE MANHOLE OPENING WITH THE CONTAINMENT. USE 4 SHORT PIECES OF 2 X 4, OR BRICKS TO LAY UNDER MANHOLE TO KEEP IT PLUMB 1" ABOVE GRADE.

**CONTINUED ON THE BACK** →



# NEW STYLE BELLOWS CONTAINMENT INSTRUCTIONS

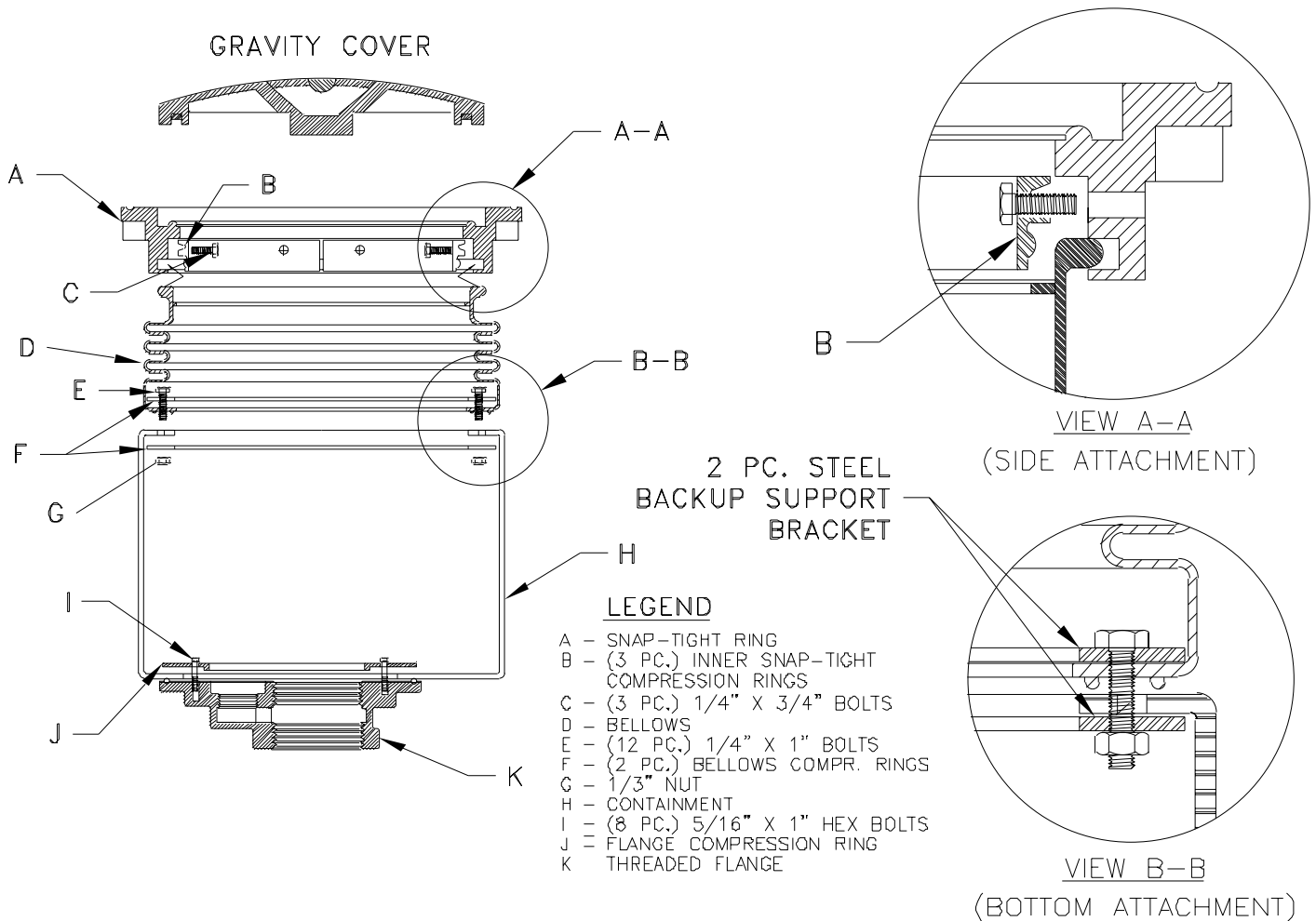

2. THE BELLOWS GASKET-(D) AND CONTAINMENT BOX-(H) ARE ASSEMBLED COMPLETE. THERE IS NO REASON TO DISSASSEMBLE THIS UNIT. (SEE VIEW B-B)
3. THE BELLOWS GASKET-(D) HAS A BEAD IN WHICH IT INTERLOCKS IN THE GRAVITY RING-(A) GROOVE (SEE VIEW A-A). THIS APPLICATION MUST BE DONE BY TAKING YOUR YOUR FINGERS AND WORKING THE BEAD IN A 360° FORM.
4. NOW YOU PLACE THE 3 INSIDE COMPRESSION RINGS-(B) ON THE INNER BOTTOM OF THE GRAVITY RING-(A) YOU TORQUE IT DOWN TO 3 TORQUE LBS.
5. COMPRESSION RING-(E) MUST BE APPLIED INSIDE THE CONTAINMENT BOX-(C) TO FASTEN CONTAINMENT AND FLANGE TOGETHER. THERE ARE (8)-5/16 X 1" HEX BOLTS-(D) ON THE OBLONG FLANGE AND (6)-5/16 X 1" HEX BOLTS-(D) ON THE ROUND FLANGE THAT BOLT THE COMPRESSION RING DOWN. BOLTS NEED TO BE TIGHTENED IN A CROSS OVER PATTERN FOR A CORRECT SEAL TO 15 TORQUE LBS.

NOTE:

BOTTOM SECTION ON BELLOWS (VIEW B-B). THE GASKET CONSISTS OF 2 BEADS THIS ALLOWS A COMPLETE SEAL AND PREVENTS ANY OUTSIDE LEAKAGE OF LIQUID.